

General Installation Manual

General Installation Manual for SANYO HIT Photovoltaic (PV) Modules.

Please read this manual completely before installing or using the modules.

This manual is applied for the following products: HIP-190NE1, HIP-180NE1

INTRODUCTION

Thank you for choosing SANYO HIT PV modules. With proper operation and maintenance, SANYO HIT PV modules will provide you with clean, renewable solar electricity for many years. Retain this manual for reference. This manual contains important information about installation, maintenance and safety. Please retain it for future reference.

Disclaimer of Liability

SANYO does not assume responsibility and expressly disclaims liability for loss, damage, or expense arising out of or in any way connected with such installation, operation use or maintenance by using this manual. SANYO assumes no responsibility for any infringement of patents or other rights of third parties that may result from use of the module.

No license is granted by implication or under any patent or patent rights. The information in this manual is believed to be reliable, but does not constitute an expressed and implied warranty. SANYO reserves the right to make changes to the product, specifications, or manual without prior notice.

General Information

The installation of solar modules requires a great degree of skill and should only be performed by qualified licensed professional, including, without limitation, licensed contractors and licensed electricians.



- All instructions should be read and understood before attempting to install, wire operate and maintain the photovoltaic module. Contact with electrically active parts of the module such as terminals can result in burns, sparks, and lethal shock whether the module is connected or disconnected.
- The installer assumes the risk of all injury that might occur during installation, including, without

limitation, the risk of electric shock.

- PV modules generate DC electrical energy when exposed to sunlight or other light sources. Although single modules produce only a low voltage and current, shocks and burns are still a potential hazard.
- To avoid the hazard of electric shock and injury, cover all over the front surface of PV modules with a dense opaque material such as the cardboard box during installing and handling modules.
- The shock hazard increases as modules are connected in parallel producing higher current. The shock hazard increases as modules are connected in series producing higher voltages.
- To avoid the hazard of electric shock, work only under dry conditions, with dry module and tools.
- Do not stand or step on a module to avoid the hazard of injury and the damage to a module.
- Do not damage the back sheet of a module, to avoid the hazard of electric shocks and fire.
- To avoid the hazard of electric shock and injury, Children and unauthorized persons should not be allowed near the installation of the solar cell modules.
- To avoid the hazard of electric shock and injury, be sure to ground the modules completely.
- To avoid the hazard of electric shock, fire and injury, do not disassemble the module, or remove any part installed by the manufacturer.
- Unauthorized persons except the qualified licensed professional should not open the cover of the junction box to avoid the hazard of electric shock.
- Do not touch terminals while a module(s) is exposed to light. Provide suitable guards to prevent yourself contacting directly with 30 VDC or greater to avoid the hazard of electric shock or injury.
- When carrying a module, more than two persons should carry it by the frame and wear non-slip gloves to avoid the hazard of injury by

slipping down the module on a foot or cutting by an edge of the frame and so on.

- Do not carry a module by wire or junction box to avoid the hazard of electric shock and injury or any troubles in a module, which it may cause.
- Do not drop anything on the surfaces of modules to avoid the hazard of electric shock and injury or any troubles that it may cause.
- To avoid the hazard of electric shock and fire, be sure that other system components do not cause any hazard of any mechanical or electrical nature to the module.
- Since sparks may be generated, do not install module where flammable gases or vapors are present.
- Never leave a module unsupported or unsecured. Do not drop module and do not allow objects to fall on module to avoid the hazard of injury or any troubles in modules that it may cause.
- Do not use or install broken modules to avoid the hazard of electric shock and injury.
- Do not artificially concentrate sunlight on module to avoid the hazard of fire or any trouble.
- Do not touch the Junction box terminals to avoid the hazard of electric shock and injury.
- Do not change wiring of bypass diodes to avoid the hazard of electric shock and injury.



- Use module for its intended function only.
- Do not treat the back sheet and front surface with paint or adhesives to avoid any troubles.

GENERAL SAFETY

Follow all permission, installation and inspection requirements

- Before installing module, contact appropriate authorities to determine permission, installation and inspection requirements that should be followed. This should be done not only for installations in conjunction with buildings, but also for marine and motor vehicle applications for which additional requirements may apply.
- Be sure that the construction intended to install modules on its rooftop has enough strength. For modules mounted on roof, special construction may be required to help provide proper installation. Both roof construction and module installation design have an effect on the fire resistance of the building. Improper installation may contribute to hazards in the event of fire. Additional devices such as ground fault, fuses and disconnects may be required.
- Do not use modules of different configurations in the same system.
- Follow all safety precautions of other used components.

INSTALLATION

General

- Please read this guide completely before installing or using the modules. This section contains electrical and mechanical specifications before using your SANYO photovoltaic modules.
- Modules should be firmly fixed in place in a manner suitable to withstand all expected loads, including wind and snow loads.
- Do not drill additional mounting holes in the module frames, as it will void the warranty.
- The appropriate material should be employed for mounting hardware to prevent the module frame, mounting structure and hardware itself from corrosion.
- Please install modules at the place where they are not shaded by the obstacles like building and trees. Especially, please pay attention to avoid partially shading modules by something in daytime.
- Please contact your local dealer with questions regarding mounting profiles for modules.

Notes on Installation

- Clearance between the module frame and the mounting surface is required to allow cooling air to circulate around the back of the module. This also allows any condensation or moisture to dissipate. The module should never be sealed to the mounting surface with sealant that prevents air from circulating under the module.
- We recommend installation method shown in Fig1. In some areas, local electrical and building codes may govern the installation and use of PV modules.

Standard Operating Condition

Standard operating condition (SOC) of our solar cell modules is as follows. It is recommended that the modules should be operated in the SOC. The installation place with conditions beyond SOC or with special conditions should be avoided.

1. Standard operating condition

- (1) The modules should be operated only in terrestrial use except space use or other use in the special conditions.
- (2) The ambient temperature should be within -20°C to 40°C .
- (3) The installation place should be less than 1000m above sea level.

2. Special conditions

- (1) The ambient temperature and installation place are different from the SOC
- (2) The salt damage is heavy at installation place.
- (3) The hail and snow damages are heavy at installation place
- (4) The sand and dust damages are heavy at installation place
- (5) Other special conditions (with air pollution, or with chemically active vapor, etc)

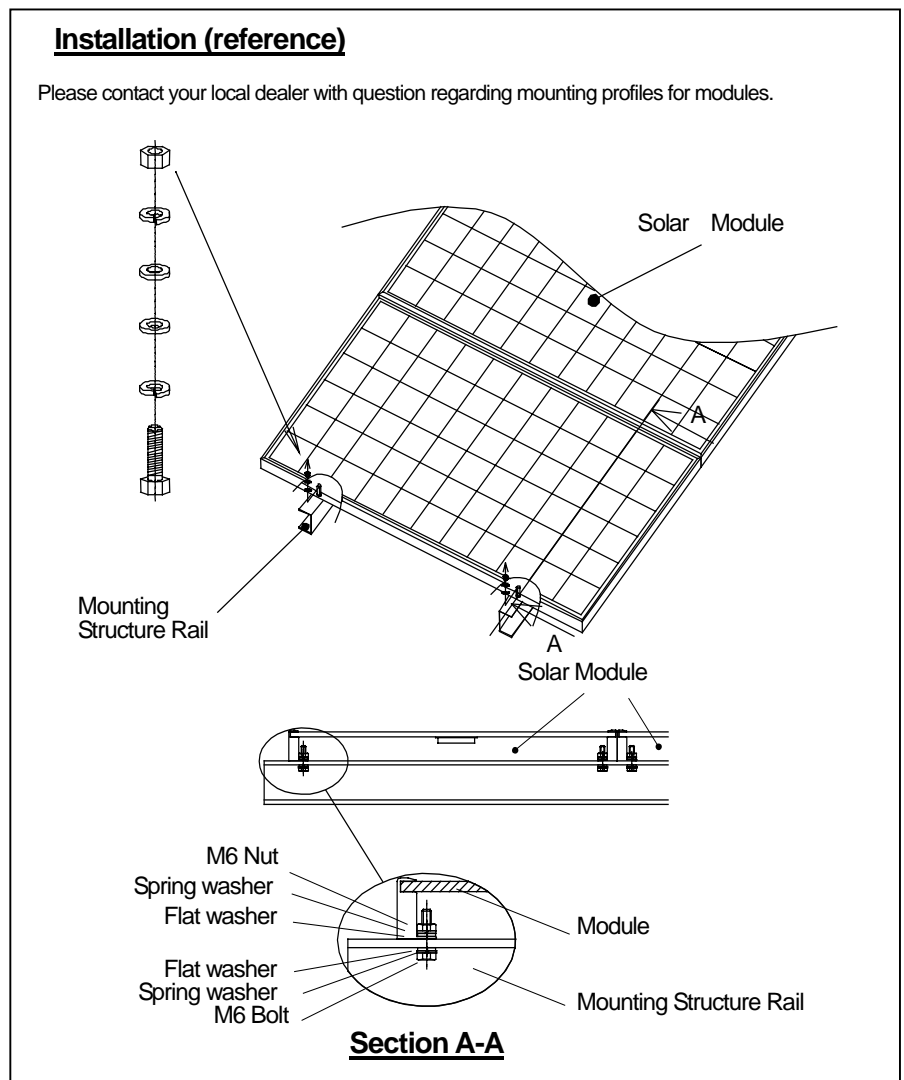

Figure1: Installation

Mechanical / Electrical Specifications

Electrical Specification		
Model	HIP -190NE1	HIP -180NE1
Cell Number in Series [Pieces]	66	66
Maximum Power (Pmax) [W]	190	180
Maximum Power Voltage (Vmp) [V]	37.6	36.5
Maximum Power Current (Imp) [A]	5.05	4.93
Open Circuit Voltage (Voc) [V]	46.4	45.5
Short Circuit Current (Isc) [A]	5.57	5.49
Cell Type	HIT* (hybrid of a-Si and mono c-Si)	
Maximum System Voltage [V]	760	760
Factory Installed Bypass Diode	Yes	Yes
Weight [kg]	14	14

*HIT= Hetero junction with Intrinsic Thin-layer

Note: The values in the above table are nominal.

SPECIFICATIONS

Notes on specification

- (1) Powered specifications are measured at Standard Test Condition Irradiance of : 1000W/m^2 , 25°C cell temperature and solar spectral irradiance per IEC 60904-3.
- (2) The current output for these modules as shown in the Specifications is measured at Standard test conditions. These conditions may not be frequently observed in actual practice.

Mechanical Loading

The modules should be mounted at the 4 or more points as shown in Fig1, Fig2. Then, a maximum loading of 2170N/m^2 (45PSF, in static state) on the module surface is possible.

CERTIFICATION

The HIP-190NE1, 180NE1 Module comply with the requirements of IEC61215, Electrical protection Class II and the CE mark.

WIRING

General

- All wiring should be done in accordance with applicable electrical codes.
- All wiring should be done by the qualified licensed professional.
- Wiring should be protected to help ensure personal safety and to prevent its damage.
- All modules connected in series should be of the same model number/type.
- Do not connect modules in parallel without using a connection box.

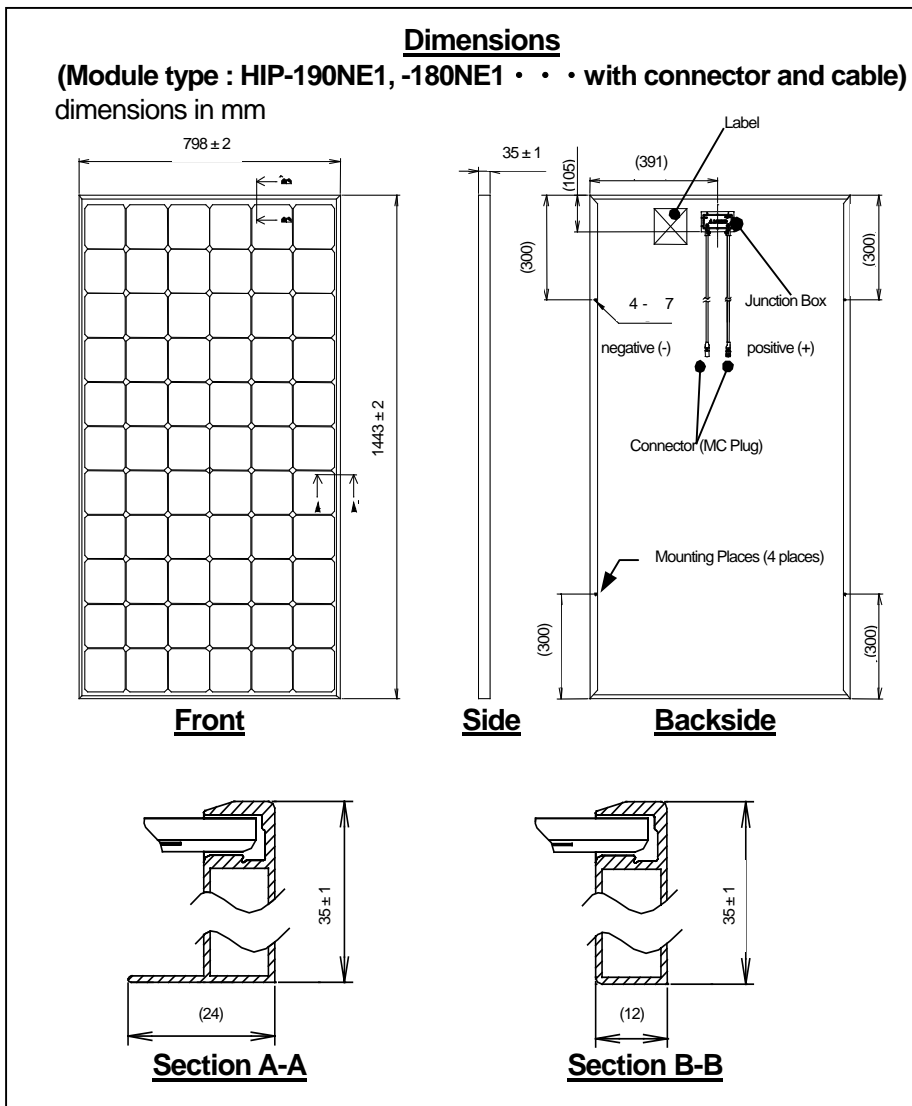

Module wiring: HIP-190NE1, HIP-180NE1

- The maximum number of HIP-190NE1, 180NE1 modules that can be wired in series is fourteen (14).
- The following SANYO solar modules, HIP-190NE1, 180NE1 are not designed to fit them to charging batteries. It is not recommended to use them to charge batteries without any measures. When you use them for charging batteries, please consult your dealer.
- These module types contain factory installed bypass diodes. If these modules are incorrectly connected each other, the bypass diodes or cable or junction box may be damaged.

Array Wiring

The term "array" is used to describe the assembly of several modules on a support structure with associated wiring. Use copper wire that is sunlight resistant and is insulated to withstand the maximum possible system open circuit voltage. Check your local codes for requirements.

Electrical Protection

The HIP-190NE1, 180NE1 Module complies with the requirements of Electrical protection Class II. If necessary, the module or array can be grounded.

Module Terminations

A junction box as terminal enclosure is equipped for electrical connections on SANYO modules. The HIP-190NE1, 180NE1 modules are equipped with MC plugs as terminal enclosure. Use these MC plugs for electrical connections. Please contact your local dealer with questions regarding other electrical connections for modules.

Junction box configuration and description of terminals (for reference)

Modules equipped with one junction box contain terminals for both positive and negative polarity, and bypass diodes.

Two terminals are dedicated to each polarity (with the polarity symbols engraved onto the body of the junction box) (see Fig3).

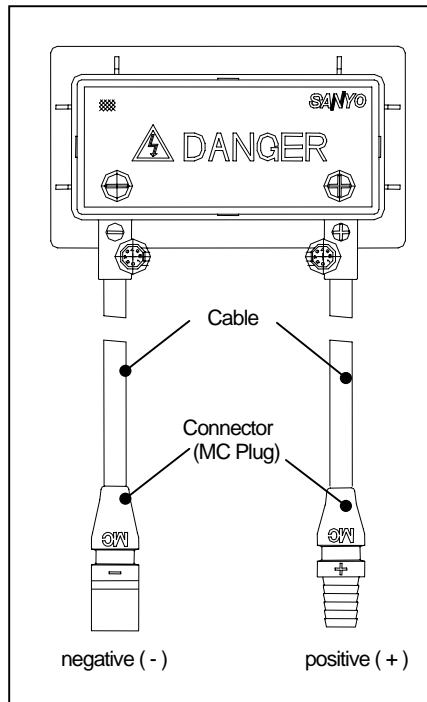

Figure3: Configuration of junction box

DIODES

Bypass Diodes

When the modules in series strings are shaded partially, it may cause a reverse voltage across cells or modules, because the current from other cells in the same series is forced to flow through the shaded area, and then undesirable heating may occur. The use of a diode to bypass the shaded area can minimize both heating and reduction of array current.

All SANYO modules are equipped with factory installed bypass diodes. The factory-installed diodes provide proper circuit protection for the systems within the specified system voltage, so that you don't need any other additional bypass diodes. Contact your authorized SANYO distributor or dealer for proper diode type, if necessary to add or change diodes due to system specification.

MAINTENANCE

Some maintenance is recommended to maintain optimal output performance of solar cell modules. If the module surface becomes dirty, it may cause reduction of output power. It is recommended to clean the surface with water and soft cloth or sponge. A mild non-abrasive detergent may be applied for the persistent dirt. And it is also recommended to inspect the electrical

and mechanical connections annually. If you need electrical and mechanical inspection or maintenance, it is recommended to have the authorized professional carry out the inspection or maintenance to avoid the hazards of electric shock or injury.

For complete information, please contact

SANYO Component Europe GmbH
Mobile & Clean Energy Division
Stahlgruberring 4
D-81829, Munich
Germany
TEL: +49-89-460095-0
FAX: +49-89-460095-190

The return of any modules will not be accepted by SANYO unless prior written authorization has been given by SANYO.

As part of our policy of continuous improvement SANYO reserves the right to change products specifications at any time without prior notice.