

The SANYO HIT (Heterojunction with Intrinsic Thin layer) solar cell is made of a thin mono crystalline silicon wafer surrounded by ultra-thin amorphous silicon layers. This product provides the industry's leading performance and value using state-of-the-art manufacturing techniques.



Benefit in Terms of Performance High efficiency cell: 17.3%, Module: 15.3%

The HIT cell and module have the world's top-level efficiency in mass production.

High performance at high temperatures

Even at high temperatures, the HIT solar cell can maintain higher efficiency than a conventional crystalline silicon solar cell.

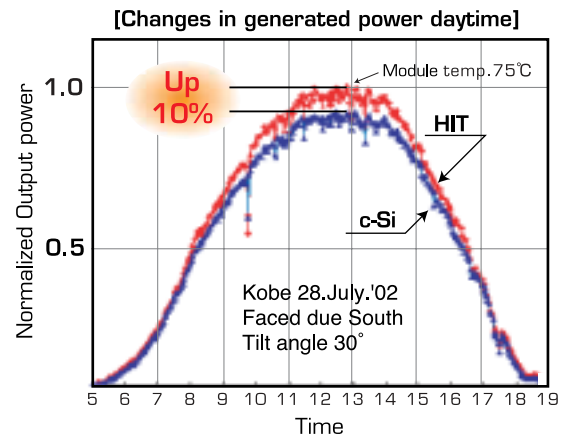

Environmental Friendly Solar Cell More Clean Energy

HIT can generate more clean Energy than other conventional crystalline solar cells.

Special Features

SANYO HIT solar modules are 100% emission free, have no moving parts and produce no noise. The dimensions of the HIT modules allow space-saving installation and achievement of maximum output power possible on given roof area.

Benefit in Terms of Quality

High quality in accordance with ISO 9001 and 14001 standards

HIT solar cell and modules are subject to strict inspections and measurements to ensure compliance with electrical, mechanical and visual criteria.

HIT Solar Cell Structure

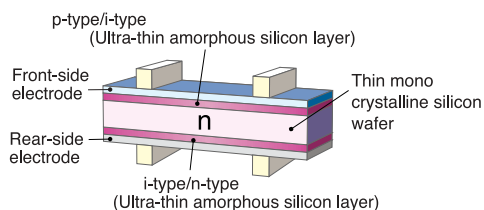

Development of HIT solar cell was supported in part by the New Energy and Industrial Technology Development Organization (NEDO).



Electrical and Mechanical Characteristics

HIP-180BE3

Electrical data

Maximum power (Pmax)	[W]	180
Max.power voltage (Vmp)	[V]	54.0
Max.power current (Imp)	[A]	3.33
Open circuit voltage (Voc)	[V]	66.4
Short circuit current (Isc)	[A]	3.65
Warranted minimum power (Pmin)	[W]	171
Output tolerance	[%]	+10/-5
Maximum system voltage	[V]	760
Temperature coefficient of Pmax	[%/°C]	- 0.33
Voc	[V/°C]	- 0.173
Isc	[mA/°C]	1.10

Note1: Standard Test Conditions: Air mass 1.5, Irradiance = 1000W/m², Cell temperature = 25°C

Note2: The values in the above table are nominal.

Dimensions and weight

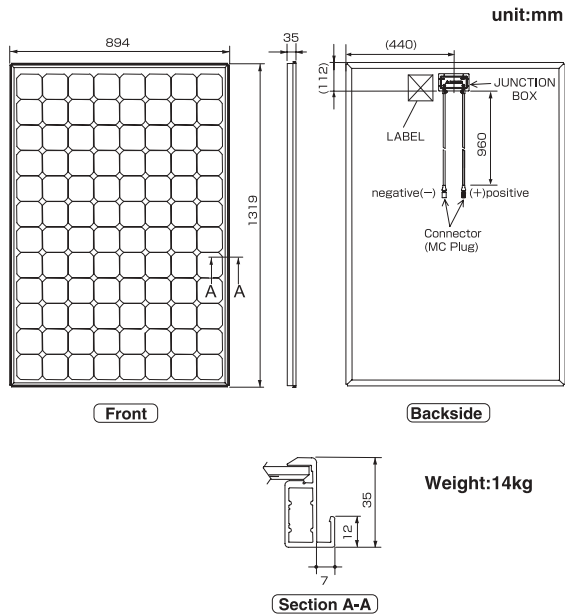

Warranty

Power output: 20 years (80% of minimum output power)
 Product workmanship : 2 years
 (Based on contact terms.)

CAUTION! Please read the operating instructions carefully before using the products.

Owing to our policy of continual improvement the products covered by this brochure may be changed without notice.

Dependence on irradiance

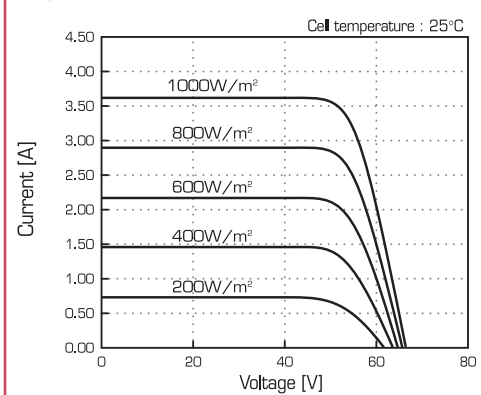

Dependence on temperature

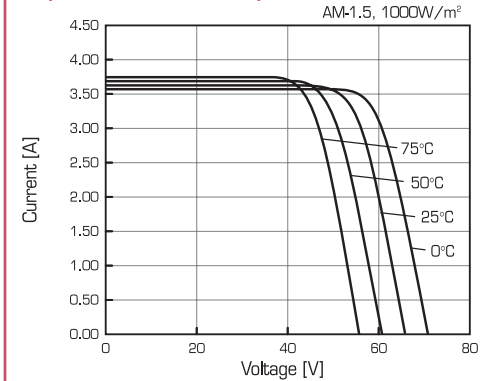

Certificates



Please consult your local dealer for more information.

SANYO Component Europe GmbH
 Clean Energy Division

Stahlgruberring 4 D-81829 Munich, Germany
 Tel. +49-(0)89-460095-0
 Fax. +49-(0)89-460095-170
 http://www.sanyo-component.com
 email: info.solar@sanyo-component.com

SANYO

SANYO Electric Co., Ltd
 Clean Energy Company

5-5 Keihan-Hondori 2, Moriguchi,
 Osaka 570-8677, Japan
 Tel. +81-(0)6-69 94-7282
 Fax. +81-(0)6-69 94-7289
 http://www.sanyo.co.jp/clean/solar/hit_e/index_e.html
 email: h_solar.1008413@sanyo.co.jp