



# SOLAR MODULE REC AE-SERIES

## DATASHEET

REC205AE  
REC210AE  
REC215AE  
REC220AE  
REC225AE  
REC230AE  
REC235AE

### UNCOMPROMISING QUALITY

The REC AE-Series is a very high quality series of solar modules designed to meet system demand with exceptional performance. Rigorous quality control via automated camera inspection systems is applied throughout the production process; from cells to modules. The multicrystalline solar cells within each module are optimized for low light conditions and increased light absorption. The surfaces of the cells are acidic etched, providing optimal cell efficiency. The high quality modules have an innovative design that minimizes or reduces shading effects in order to achieve maximum performance. A power output tolerance of  $\pm 5\%$  guarantees minimum mismatch losses. User manual and mounting system information are available upon request.

### QUICK INSTALLATION

The REC AE-Series allows quick and easy installation. The modules are equipped together with MC FlexSol solar cables, together with MC III connectors for problem-free inter-module connection.

### ENVIRONMENTALLY FRIENDLY PRODUCTS & PROCESSES

The REC AE-Series series generate reliable and environmentally friendly electricity. The cell and module production processes are designed to maximize recycling and reduce environmental impact. REC's wafers, cells and modules are produced within Scandinavia and our activities are therefore subject to very high standards of regulation regarding environmental issues.

### CUSTOMER SATISFACTION GUARANTEE

The REC AE-Series module comes with a guarantee of 90% of rated power output for 10 years and 80% of rated power output for 25 years. Furthermore it comes with a 5 year limited warranty on materials and workmanship.

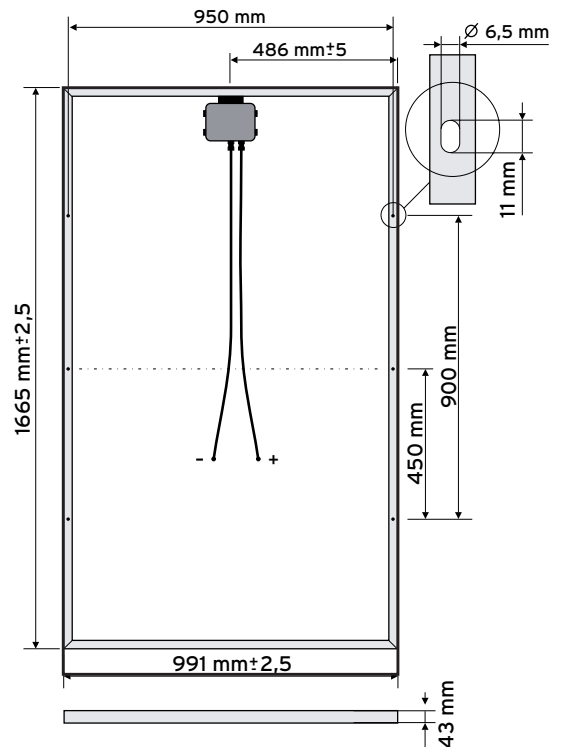
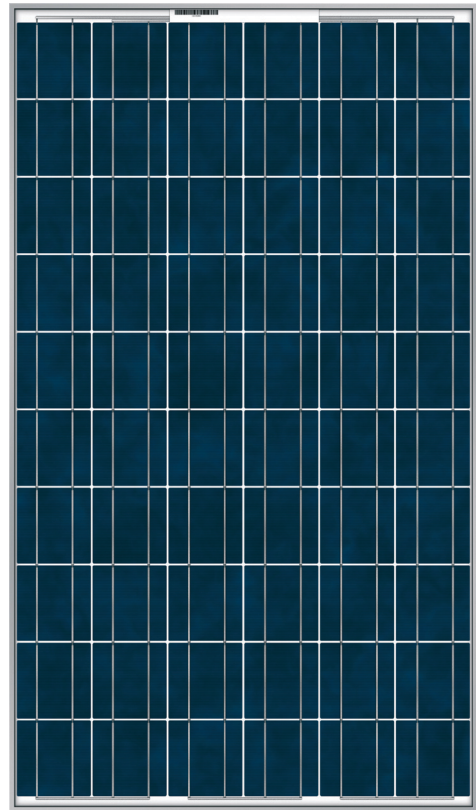

MODEL	REC205AE	REC210AE	REC215AE	REC220AE	REC225AE	REC230AE	REC235AE
<b>ELECTRICAL DATA</b>							
Peak Power Watts - Pmpp (Wp)	205	210	215	220	225	230	235
Power Output Tolerance - Pmpp (%)	±5	±5	±5	±5	±5	±5	±5
Maximum Power Voltage - Vmpp (V)	27.2	27.6	28.0	28.4	28.8	29.1	29.5
Maximum Power Current - Impp (A)	7.6	7.6	7.7	7.8	7.8	7.9	8.0
Open Circuit Voltage - Voc (V)	36.0	36.1	36.3	36.4	36.6	36.8	36.9
Short Circuit Current - Isc (A)	8.3	8.3	8.3	8.4	8.4	8.4	8.5
Temperature Coefficient of Pmpp (%/°C)	- 0.452	- 0.452	- 0.452	- 0.452	- 0.452	- 0.452	-0.452
Temperature Coefficient of Voc (%/°C)	- 0.34	- 0.34	- 0.34	- 0.34	- 0.34	- 0.34	-0.34
Temperature Coefficient of Isc (%/°C)	0.074	0.074	0.074	0.074	0.074	0.074	0.074
Module Efficiency (%)	12.4	12.7	13.0	13.3	13.6	13.9	14.2
Max Series Fuse Rating (A)	15	15	15	15	15	15	15

Values at Standard Test Conditions STC (Air Mass AM 1.5, Irradiance 1000 W/m<sup>2</sup>, Cell temperature 25 °C)

**NOCT (Nominal Operating Cell Temperature)** 47.5°C ±2

The NOCT values are reached at an irradiance of 800 W/m<sup>2</sup>, at an ambient temperature of 68 °F [20 °C] and a wind speed of 1 m/s.

Performance measurements at different low irradiance levels: 800 W/m<sup>2</sup> = - 19.6%, 500 W/m<sup>2</sup> = - 49.8%, 200 W/m<sup>2</sup> = - 80.6%.

**SIZE AND WEIGHT**

**AE-SERIES**

Area (m <sup>2</sup> )	1.65
Length (mm)	1665
Width (mm)	991
Thickness with frame (mm)	43
Weight (kg)	22

**OPERATION LIMITS**

Maximum System Voltage:	1000 V
Module temperature range:	- 40... + 80 °C
Maximum load:	551 kg/m <sup>2</sup> (5400 Pa)
Storm proof:	wind speed of up to 197 km/h and security factor 3.

**GENERAL**

**Cells**

Multi-crystalline cells: 156 mm x 156 mm, 60 in series

**Module**

Front:	High-transparency solar glass with antireflection surface treatment.
Encapsulation:	EVA
Backsheet:	TPT
Junction box:	Easy access, 3 x 12A bypass diodes.
Frame:	Anodized aluminum.

**Connection**

2 x 0.94 m solar cables with MC III connectors.



**CERTIFICATION / STANDARDS**

Complies to IEC 61215 2. edition and TÜV Safety Class II

Note: Specifications subject to change without notice.



For further information contact your local distributor or visit our web site:

**www.recgroup.com**