

167 WATT

POWERFUL. ATTRACTIVE. RELIABLE.

POLY-CRYSTALLINE SILICON PHOTOVOLTAIC MODULE WITH 167W MAXIMUM POWER

Sharp's ND-167U1Y photovoltaic modules offer industry-leading performance and aesthetics. Designed for use specifically with Sharp's Solar Racking System (SRS), these residential modules give the clean, attractive appearance of a high-tech skylight while the black anodized aluminum frames and trim strips blend beautifully with the home's exterior. Using breakthrough technology perfected by Sharp's 45 years of research and development, these modules incorporate an advanced surface texturing process to increase light absorption and improve efficiency. Sharp's ND-167U1Y modules are the perfect combination of technology and aesthetics.

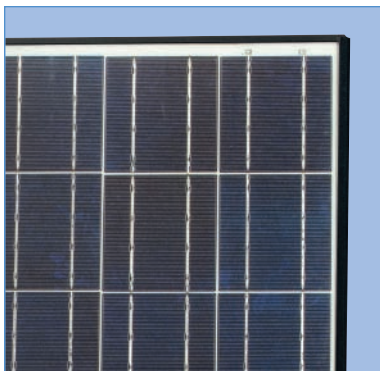

The laminated glass module is glazed into a high torsion black anodized aluminum frame.



Sharp's residential modules with black frames and trim strips are ideal for peak roofs, and allow for the seamless integration of the system into the home's design.

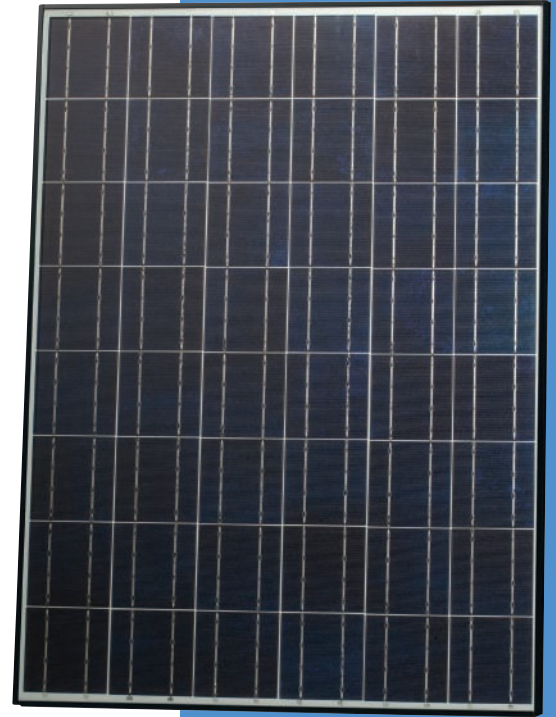

FEATURES

- High-power module (167W) using 156mm square poly-crystalline silicon solar cells with 12.7% module conversion efficiency
- Sharp's advanced surface texturing process increases light absorption and efficiency while providing a more subdued, "natural" look
- Bypass diodes minimize the power drop caused by shade
- Black anodized aluminum frame and "L" hook design located along frame perimeter for easy integration with SRS mounting hardware
- Water white, tempered glass, EVA laminate, and a weatherproof film yield long-life modules while enhancing cell performance
- UL Listings: UL 1703, cUL
- Manufactured in ISO 9001 certified facilities
- 25-year limited warranty on power output (see dealer for details)

ELECTRICAL CHARACTERISTICS

Cell	Poly-crystalline silicon
No. of Cells and Connections	48 in series
Open Circuit Voltage (Voc)	29.04V
Maximum Power Voltage (Vpm)	22.97V
Short Circuit Current (Isc)	8.02A
Maximum Power Current (Ipm)	7.27A
Rated Power (Pmax)*	167W (+10% / -5%)
Module Efficiency (ηm)	12.7%
Maximum System Voltage	600VDC
Series Fuse Rating	15A
Type of Output Terminal	Lead Wire with MC Connector

* (STC) Standard Test Conditions: 25°C, 1 kW/m², AM 1.5

MECHANICAL CHARACTERISTICS

Dimensions (A x B x C below)	52.3" x 39.1" x 2.26"/ 1328 x 994 x 57.5mm
Weight	36.4lbs / 16.5kg
Size of Carton	56.3" x 42.5" x 5.1" / 1430 x 1080 x 130mm
Packing Configuration	2 pcs per carton
Loading Capacity (20 ft container)	224 pcs (112 cartons)
Loading Capacity (40 ft container)	504 pcs (252 cartons)
Loading Capacity (53 ft container)	560 pcs (280 cartons)

ABSOLUTE MAXIMUM RATINGS

Operating Temperature	-40 to +194°F / -40 to +90°C
Storage Temperature	-40 to +194°F / -40 to +90°C

IV CURVES

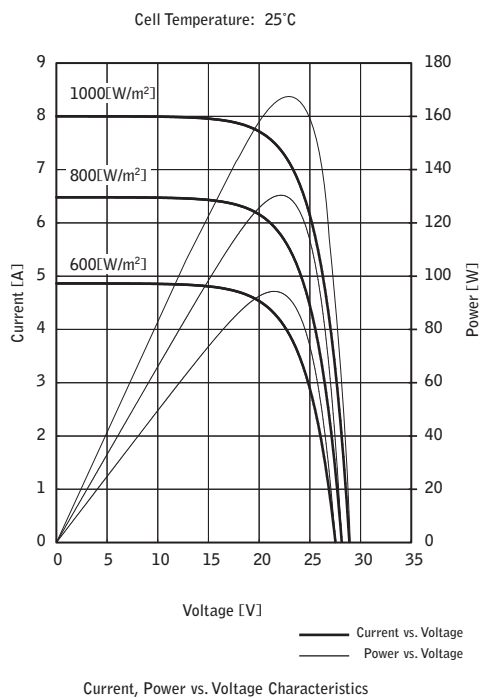

DIMENSIONS

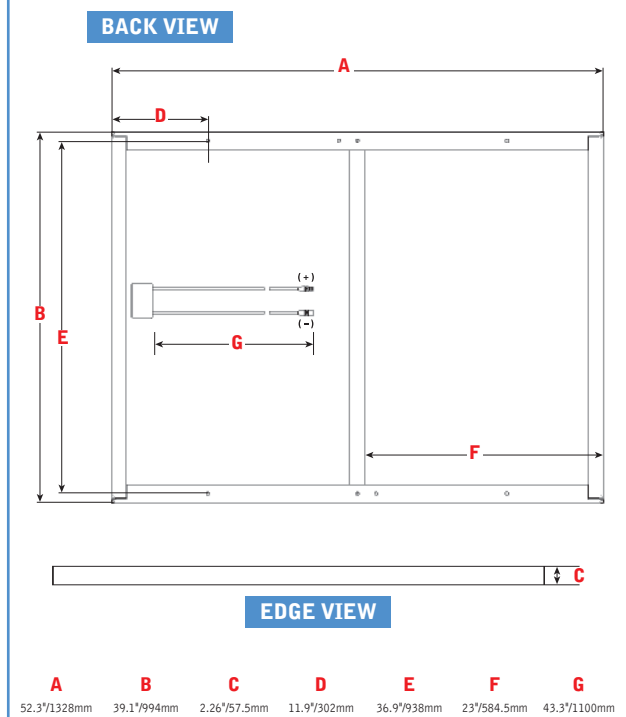

Design and specifications are subject to change without notice.

Sharp is a registered trademark of Sharp Corporation. All other trademarks are property of their respective owners.

Sharp takes no responsibility for any defects that may occur in equipment using any Sharp devices.

Contact Sharp to obtain the latest product manuals before using any Sharp device.

